

MIG 180

Operating manual



Welcome to a better way of welding.

This operating manual provides the basic knowledge required for MIG/MAG welding, as well as highlighting important areas of how to operate the Smootharc MIG 180 machine.

With normal use and by following these recommended steps, your Smootharc MIG 180 machine can provide you with years of trouble-free service. Smootharc equipment and technical support is available through the national BOC Customer Service Centre or contact your local Gas & Gear outlet.

Important Notice

This document has been prepared by BOC Limited ABN 95 000 029 729 ('BOC'), as general information and does not contain and is not to be taken as containing any specific recommendation. The document has been prepared in good faith and is professional opinion only. Information in this document has been derived from third parties, and though BOC believes it to be reliable as at the time of printing, BOC makes no representation or warranty as to the accuracy, reliability or completeness of information in this document and does not assume any responsibility for updating any information or correcting any error or omission which may become apparent after the document has been issued. Neither BOC nor any of its agents has independently verified the accuracy of the information contained in this document. The information in this document is commercial in confidence and is not to be reproduced. The recipient acknowledges and agrees that it must make its own independent investigation and should consider seeking appropriate professional recommendation in reviewing and evaluating the information. This document does not take into account the particular circumstances of the recipient and the recipient should not rely on this document in making any decisions, including but not limited to business, safety or other operations decisions. Except insofar as liability under any statute cannot be excluded, BOC and its affiliates, directors, employees, contractors and consultants do not accept any liability (whether arising in contract, tort or otherwise) for any error or omission in this document or for any resulting loss or damage (whether direct, indirect, consequential or otherwise) suffered by the recipient of this document or any other person relying on the information contained herein. The recipient agrees that it shall not seek to sue or hold BOC or their respective agents liable in any such respect for the provision of this document or any other information.

Contents.

1.0	Recommended Safety Guidelines and Precautions	4
1.1	Health Hazard Information	5
1.2	Personal Protection	5
1.3	Electrical shock	7
1.4	User Responsibility	7
2.0	MIG/MAG Operating Manual	8
2.1	Introduction to Metal Inert Gas (MIG) & Metal Active Gas (MAG)	8
2.2	Introduction to Flux Cored Arc Welding (FCAW)	8
2.3	Introduction to Metal Cored Arc Welding (MCAW)	10
2.4	Modes of metal transfer	11
2.5	Fundamentals of MIG/MAG, FCAW and MCAW	13
2.6	4T/2T Trigger Latch Selection	15
3.0	General Welding Information	16
3.1	Recommended Welding Parameters for MIG/MAG	16
4.0	Correct Application Techniques	17
5.0	Package Contents	19
6.0	Smootharc MIG 180 Installation	20
6.1	Installation for MIG/MAG process	20
7.0	Control panel	21
8.0	Smootharc MIG 180 Operation	22
8.1	Starting up	22
8.2	Operation instruction	23
9.0	Troubleshooting and Fault Finding	25
9.1	MIG/MAG functions	25
10.0	Periodic Maintenance	27
10.1	Power Source	27
11.0	Technical Specifications	28
12.0	Warranty Information	29
12.1	Terms of Warranty	29
12.2	Limitations on Warranty	29
12.3	Warranty Period	29
12.4	Warranty Repairs	29

1.0 Recommended Safety Guidelines and Precautions

Diagram and safety explanation



Electrical safety alert



Welding electrode causing electric shock



Fumes and gases coming from welding process



Welding arc rays



Read instruction manual



Become trained



Wear dry, insulated gloves



Insulate yourself from work and ground



Disconnect input power before working on equipment



Keep head out of fumes



Use forced ventilation or local exhaust to remove fumes



Use welding helmet with correct shade of filter

Some safety precautions BOC recommends are as follows:

- Repair or replace defective cables immediately.
- Never watch the arc except through lenses of the correct shade.
- In confined spaces, adequate ventilation and constant observation are essential.
- Leads and cables should be kept clear of passageways.
- Keep fire extinguishing equipment at a handy location in the workshop.
- Keep primary terminals and live parts effectively covered.
- Never strike an arc on any gas cylinder.
- Never use oxygen for venting containers.

1.1 Health Hazard Information

The actual process of welding is one that can cause a variety of hazards. All appropriate safety equipment should be worn at all times, i.e. headwear, hand and body protection. Electrical equipment should be used in accordance with the manufacturer's recommendations.

Eyes

The process produces ultra violet rays that can injure and cause permanent damage. Fumes can cause irritation.

Skin

Arc rays are dangerous to uncovered skin.

Inhalation

Welding fumes and gases are dangerous to the health of the operator and to those in close proximity. The aggravation of pre-existing respiratory or allergic conditions may occur in some workers. Excessive exposure may cause conditions such as nausea, dizziness, dryness and irritation of eyes, nose and throat.

1.2 Personal Protection

Respiratory

Confined space welding should be carried out with the aid of a fume respirator or air supplied respirator as per AS/NZS 1715 and AS/NZS 1716 Standards.

- You must always have enough ventilation in confined spaces. Be alert to this at all times.
- Keep your head out of the fumes rising from the arc.

- Fumes from the welding of some metals could have an adverse effect on your health. Don't breathe them in. If you are welding on material such as stainless steel, nickel, nickel alloys or galvanised steel, further precautions are necessary.
- Wear a respirator when natural or forced ventilation is insufficient.

Eye protection

A welding helmet with the appropriate welding filter lens for the operation must be worn at all times in the work environment. The welding arc and the reflecting arc flash gives out ultraviolet and infrared rays. Protective welding screen and goggles should be provided for others working in the same area.

Recommended filter shades for arc welding

Less than 150 amps	Shade 10*
150 to 250 amps	Shade 11*
250 to 300 amps	Shade 12
300 to 350 amps	Shade 13
Over 350 amps	Shade 14

*Use one shade darker for aluminium.

Clothing

Suitable clothing must be worn to prevent excessive exposure to UV radiation and sparks. An adjustable helmet, flameproof loose-fitting cotton clothing buttoned to the neck, protective leather gloves, spats, apron and steel capped safety boots are highly recommended.

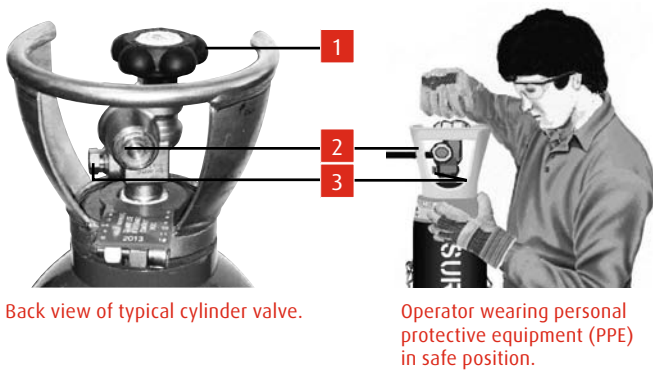

Back view of typical cylinder valve.

Operator wearing personal protective equipment (PPE) in safe position.



Cylinder safety diagram

- 1 Cylinder valve hand-wheel
- 2 Back-plug
- 3 Bursting disc

Ten points about cylinder safety

- 1 Always read the labels and Safety Data Sheet (SDS) before use.
- 2 Store cylinders upright and use in well-ventilated, secure areas away from pedestrian or vehicle thoroughfares.
- 3 Ensure cylinders are appropriately secured and guarded against being knocked violently or being allowed to fall.
- 4 Wear safety shoes, glasses and gloves when handling, connecting and using cylinders.
- 5 Ensure cylinders are appropriately restrained to mechanical lifting/handling devices prior to movement.
- 6 Keep in a cool, well-ventilated area, away from heat sources, sources of ignition and combustible materials, especially flammable gases.
- 7 Keep full and empty cylinders separate.
- 8 Keep ammonia-based leak detection solutions, oil and grease away from cylinders and valves.
- 9 Never use force when opening or closing valves.
- 10 Never repaint or disguise markings and damage on cylinders. If damaged, return cylinders to BOC immediately.

Cylinder valve safety

When working with cylinders or operating cylinder valves, ensure that you wear appropriate protective clothing – gloves, boots and safety glasses.

Ensure cylinder valve is closed before moving or disconnecting equipment.

Before operating a cylinder valve

Ensure that the system you are connecting the cylinder into is suitable for the gas and pressure involved.

Cylinder valves should not be open unless a pressure regulator has been fitted.

Ensure that any accessories (such as hoses attached to the cylinder valve, or the system being connected to) are securely connected. A hose, for example, can potentially flail around dangerously if it is accidentally pressurised when not restrained at both ends.

Stand to the side of the cylinder so that neither you nor anyone else is in line with the back of the cylinder valve. This is in case a back-plug is loose or a bursting disc vents. The correct stance is shown in the diagram above.

When operating the cylinder valve

Open it by hand by turning the valve hand-wheel anti-clockwise. Use only reasonable force.

Ensure that no gas is leaking from the cylinder valve connection or the system to which the cylinder is connected. DO NOT use ammonia-based leak detection fluid as this can damage the valve. Approved leak detection fluid, can be obtained from a BOC Gas & Gear centre.

When finished with the cylinder, close the cylinder valve by hand by turning the valve hand-wheel in a clockwise direction. Use only reasonable force.

Remember NEVER tamper with the valve.

If you suspect the valve is damaged, DO NOT use it. Report the issue to BOC and arrange for the cylinder to be returned to BOC.

1.3 Electrical shock

- Never touch 'live' electrical parts.
- Always repair or replace worn or damaged parts.
- Disconnect power source before performing any maintenance or service.
- Earth all work materials.
- Never work in moist or damp areas.

Avoid electric shock by:

- Wearing dry insulated boots.
- Wearing dry leather gloves.
- Working on a dry insulated floor where possible.

1.4 User Responsibility

- Read the Operating Manual prior to installation of this machine.
- Unauthorised repairs to this equipment may endanger the technician and operator and will void your warranty. Only qualified personnel approved by BOC should perform repairs.
- Always disconnect mains power before investigating equipment malfunctions.
- Parts that are broken, damaged, missing or worn should be replaced immediately.
- Equipment should be cleaned periodically.

BOC stocks a huge range of personal protective equipment. This, combined with BOC's extensive Gas and Gear network, ensures fast, reliable service throughout the South Pacific.

STOP

PLEASE NOTE that under no circumstances should any equipment or parts be altered or changed in any way from the standard specification without written permission given by BOC. To do so, will void the Equipment Warranty.

Further information can be obtained from Welding Institute of Australia (WTIA) Technical Note No.7.

Health and Safety Welding
Published by WTIA,
PO Box 6165 Silverwater NSW 2128

Phone (02) 9748 4443

2.0 MIG/MAG Operating Manual

Typical MIG/MAG set up

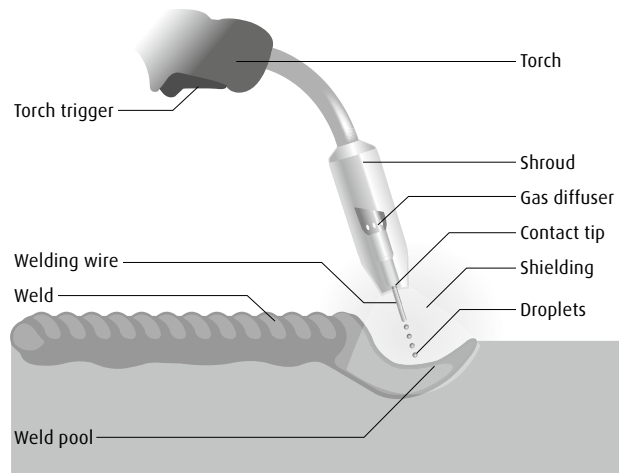

2.1 Introduction to Metal Inert Gas (MIG) & Metal Active Gas (MAG)

MIG/MAG welding embraces a group of arc welding processes in which a continuous electrode (the wire) is fed by powered feed rolls (wire feeder) into the weld pool. An electric arc is created between the tip of the wire and the weld pool. The wire is progressively melted at the same speed at which it is being fed and forms part of the weld pool. Both the arc and the weld pool are protected from atmospheric contamination by a shield of inert (non-reactive) gas, which is delivered through a nozzle that is concentric with the welding wire guide tube.

Operation

MIG/MAG welding is usually carried out with a handheld torch as a semi-automatic process. The MIG/MAG process can be suited to a variety of job requirements by choosing the correct shielding gas, electrode (wire) size and welding parameters. Welding parameters include the voltage, travel speed, arc (stick-out) length and wire feed rate. The arc voltage and wire feed rate will determine the filler metal transfer method.

This application combines the advantages of continuity, speed, comparative freedom from distortion and the reliability of automatic welding with the versatility and control of manual welding. The process is also suitable for mechanised set-ups, and its use in this respect is increasing.

MIG/MAG welding can be carried out using solid wire, flux cored, or a copper-coated solid wire electrode. The shielding gas or gas mixture may consist of the following:

- Argon (MIG)
- Carbon dioxide (MAG)
- Argon and carbon dioxide mixtures (MAG)

- Argon with oxygen mixtures (MAG)
- Argon with helium mixtures (MIG)

Each gas or gas mixture has specific advantages and limitations. Other forms of MIG/MAG welding include using a flux-cored continuous electrode and carbon dioxide shielding gas, or using self-shielding flux-cored wire, requiring no shielding.

2.2 Introduction to Flux-Cored Arc Welding (FCAW)

How it Works

Flux-cored arc welding (FCAW) uses the heat generated by a DC electric arc to fuse the metal in the joint area, the arc being struck between a continuously fed consumable filler wire and the workpiece, melting both the filler wire and the workpiece in the immediate vicinity. The entire arc area is covered by a shielding gas, which protects the molten weld pool from the atmosphere.

FCAW is a variant of the MIG/MAG process and while there are many common features between the two processes, there are also several fundamental differences.

As with MIG/MAG, direct current power sources with constant voltage output characteristics are normally employed to supply the welding current. With flux-cored wires the terminal that the filler wire is connected to depends on the specific product being used, some wires running electrode positive, others running electrode negative. The work return is then connected to the opposite terminal. It has also been found that the output characteristics of the power source can have an effect on the quality of the welds produced.

Extended self shielded flux cored wire nozzle

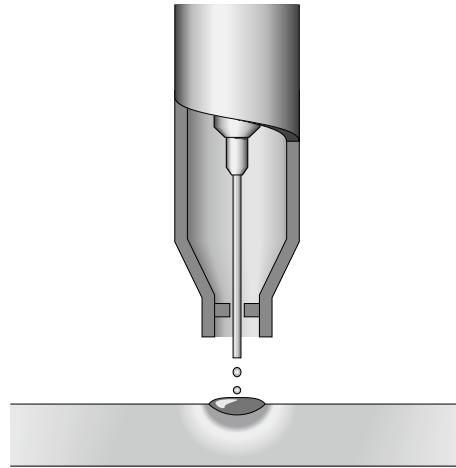

The wire feed unit takes the filler wire from a spool, and feeds it through the welding torch, to the arc at a predetermined and accurately controlled speed. Normally, special knurled feed rolls are used with flux-cored wires to assist feeding and to prevent crushing the consumable.

Unlike MIG/MAG, which uses a solid consumable filler wire, the consumable used in FCAW is of tubular construction, an outer metal sheath being filled with fluxing agents plus metal powder. The flux fill is also used to provide alloying, arc stability, slag cover, de-oxidation, and, with some wires, gas shielding.

In terms of gas shielding, there are two different ways in which this may be achieved with the FCAW process.

- Additional gas-shielding supplied from an external source, such as a gas cylinder
- Production of a shielding gas by decomposition of fluxing agents within the wire, self-shielding

Gas shielded wires are available with either a basic or rutile flux fill, while self-shielded wires have a broadly basic-type flux fill. The flux fill dictates the way the wire performs, the properties obtainable, and suitable applications.

Gas-shielded Operation

Many cored wire consumables require an auxiliary gas shield in the same way that solid wire MIG/MAG consumables do. These types of wire are generally referred to as 'gas-shielded'.

Using an auxiliary gas shield enables the wire designer to concentrate on the performance characteristics, process tolerance, positional capabilities, and mechanical properties of the products.

In a flux cored wire the metal sheath is generally thinner than that of a self-shielded wire. The area of this metal sheath surrounding the flux

cored wire is much smaller than that of a solid MIG/MAG wire. This means that the electrical resistance within the flux cored wire is higher than with solid MIG/MAG wires and it is this higher electrical resistance that gives this type of wire some of its novel operating properties.

One often-quoted property of fluxed cored wires are their higher deposition rates than solid MIG/MAG wires. What is often not explained is how they deliver these higher values and whether these can be utilised. For example, if a solid MIG/MAG wire is used at 250 amps, then exchanged for a flux cored wire of the same diameter, and welding power source controls are left unchanged, then the current reading would be much less than 250 amps, perhaps as low as 220 amps. This is because of Ohms Law that states that as the electrical resistance increases if the voltage remains stable then the current must fall.

To bring the welding current back to 250 amps it is necessary to increase the wire feed speed, effectively increasing the amount of wire being pushed into the weld pool to make the weld. It is this affect that produces the 'higher deposition rates' that the flux cored wire manufacturers claim for this type of product. Unfortunately in many instances the welder has difficulty in utilising this higher wire feed speed and must either increase the welding speed or increase the size of the weld. Often in manual applications neither of these changes can be implemented and the welder simply reduces the wire feed speed back to where it was and the advantages are lost. However, if the process is automated in some way then the process can show improvements in productivity.

It is also common to use longer contact tip to workplace distances with flux cored arc welding than with solid wire MIG/MAG welding and this also has the effect of increasing the resistive heating on the wire further accentuating the drop in welding current. Research has also shown that increasing this distance can lead to an increase in the ingress of

Process Schematic Diagram for MIG/MAG, FCAW and MCAW

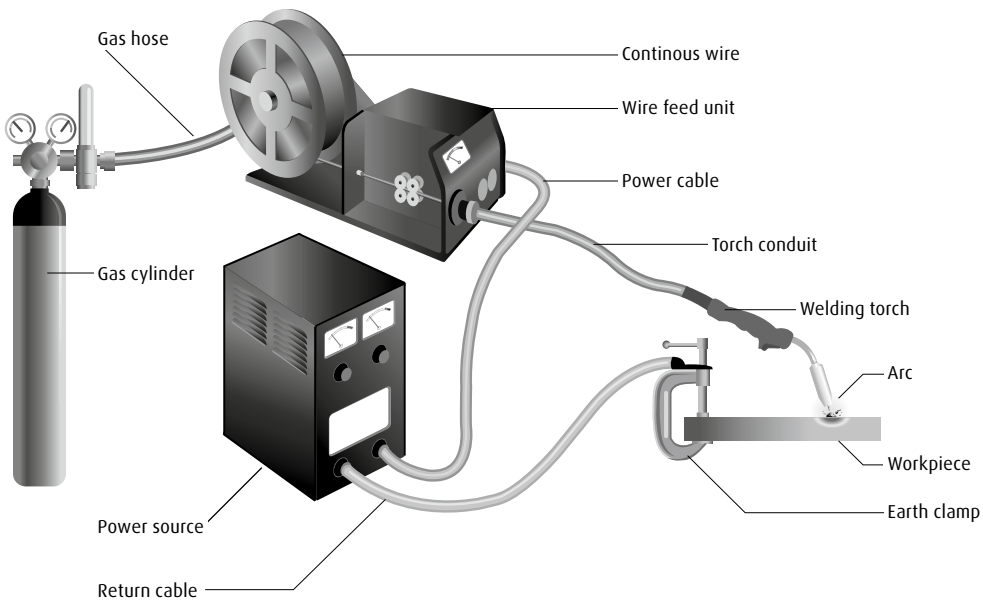

nitrogen and hydrogen into the weld pool, which can affect the quality of the weld.

Flux-cored arc welding has a lower efficiency than solid wire MIG/MAG welding because part of the wire fill contains slag-forming agents. Although the efficiency varies differs by wire type and manufacturer, it is typically between 75-85%.

Flux-cored arc welding does, however, have the same drawback as solid wire MIG/MAG in terms of gas disruption by wind, and screening is always necessary for site work. It also incurs the extra cost of shielding gas, but this is often outweighed by gains in productivity.

Self-shielded Operation

There are also self-shielded consumables designed to operate without an additional gas shield. In this type of product, arc shielding is provided by gases generated by decomposition of some constituents within the flux fill. These types of wire are referred to as 'self-shielded'.

If no external gas shield is required, then the flux fill must provide sufficient gas to protect the molten pool and to provide de-oxidisers and nitride formers to cope with atmospheric contamination. This leaves less scope to address performance, arc stabilisation, and process tolerance, so these tend to suffer when compared with gas shielded types.

Wire efficiencies are also lower, at about 65%, in this mode of operation than with gas-shielded wires. However, the wires do have a distinct advantage when it comes to site work in terms of wind tolerance, as there is no external gas shield to be disrupted.

When using self-shielded wires, external gas supply is not required and, therefore, the gas shroud is not necessary. However, an extension nozzle is often used to support and direct the long electrode extensions that are needed to obtain high deposition rates.

2.3 Introduction to Metal-Cored Arc Welding (MCAW)

How it Works

Metal-cored arc welding (MCAW) uses the heat generated by a DC electric arc to fuse metal in the joint area, the arc being struck between a continuously fed consumable filler wire and the workpiece, melting both the filler wire and the workpiece in the immediate vicinity. The entire arc area is covered by a shielding gas, which protects the molten weld pool from the atmosphere.

As MCAW is a variant of the MIG/MAG welding process there are many common features between the two processes, but there are also several fundamental differences.

As with MIG/MAG, direct current power sources with constant voltage output characteristics are normally employed to supply the welding current. With metal-cored wires the terminal the filler wire is connected to depends on the specific product being used, some wires are designed to run on electrode positive, others preferring electrode negative, and some which will run on either. The work return lead is then connected to the opposite terminal. Electrode negative operation will usually give better positional welding characteristics. The output characteristics of the power source can have an effect on the quality of the welds produced.

The wire feed unit takes the filler wire from a spool or bulk pack, and feeds it through the welding torch, to the arc at a predetermined and accurately controlled speed. Normally, special knurled feed rolls are used with metal-cored wires to assist feeding and to prevent crushing the consumable.

Unlike MIG/MAG, which uses a solid consumable filler wire, the consumable used in MCAW is of tubular construction, an outer metal

Schematic of Dip Transfer

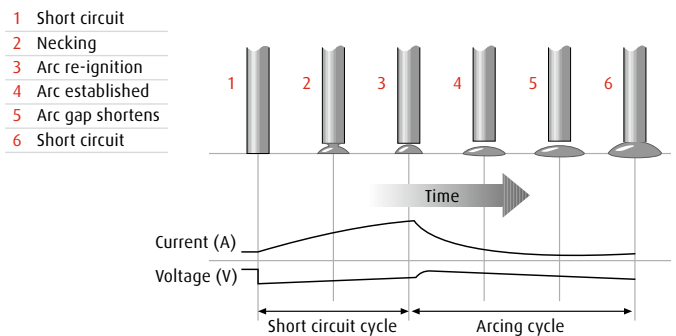

sheath being filled entirely with metal powder except for a small amount of non-metallic compounds. These are added to provide some arc stability and de-oxidation.

MCAW consumables always require an auxiliary gas shield in the same way that solid MIG/MAG wires do. Wires are normally designed to operate in argon-carbon dioxide or argon-carbon dioxide-oxygen mixtures or carbon dioxide. Argon rich mixtures tend to produce lower fume levels than carbon dioxide.

As with MIG/MAG, the consumable filler wire and the shielding gas are directed into the arc area by the welding torch. In the head of the torch, the welding current is transferred to the wire by means of a copper alloy contact tip, and a gas diffuser distributes the shielding gas evenly around a shroud which then allows the gas to flow over the weld area. The position of the contact tip relative to the gas shroud may be adjusted to limit the minimum electrode extension.

Modes of metal transfer with MCAW are very similar to those obtained in MIG/MAG welding, the process being operable in both 'dip transfer' and 'spray transfer' modes. Metal-cored wires may also be used in pulse transfer mode at low mean currents, but this has not been widely exploited.

2.4 Modes of metal transfer

The mode or type of metal transfer in MIG/MAG and MCAW welding depends upon the current, arc voltage, electrode diameter and type of shielding gas used. In general, there are four modes of metal transfer.

Modes of metal transfer with FCAW are similar to those obtained in MIG/MAG welding, but here the mode of transfer is heavily dependent on the composition of the flux fill, as well as on current and voltage.

The most common modes of transfer in FCAW are:

- Dip transfer
- Globular transfer
- Spray transfer
- Pulsed arc transfer operation has been applied to flux-cored wires but, as yet, is not widely used because the other transfer modes are giving users what they require, in most cases.

Dip Transfer

Also known as short-circuiting arc or short-arc, this is an all-positional process, using low heat input. The use of relatively low current and arc voltage settings cause the electrode to intermittently short-circuit with the weld pool at a controlled frequency. Metal is transferred by the wire tip actually dipping into the weld pool and the short-circuit current is sufficient to allow the arc to be re-established. This short-circuiting mode of metal transfer effectively extends the range of MIG/MAG welding to lower currents so thin sheet material can readily be welded. The low heat input makes this technique well-suited to the positional welding of root runs on thick plate, butt welds for bridging over large gaps and for certain difficult materials where heat input is critical. Each short-circuit causes the current to rise and the metal fuses off the end of the electrode. A high short-circuiting frequency gives low heat input. Dip transfer occurs between ± 70 -220A, 14-23 arc volts. It is achieved using shielding gases based on carbon dioxide and argon.

Metal-cored wires transfer metal in dip mode at low currents just like solid MIG/MAG wires. This transfer mode is used for all positional work with these types of wire.

Schematic of Globular Transfer

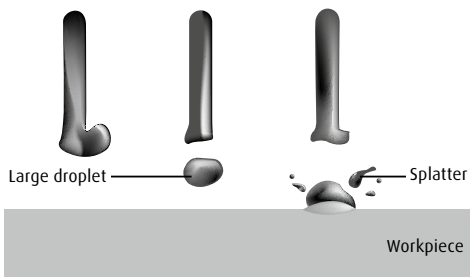

Schematic of Spray Transfer

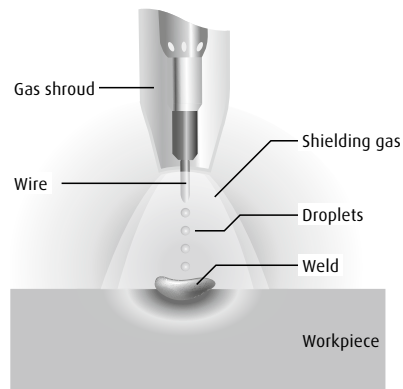

Globular Transfer

Metal transfer is controlled by slow ejection resulting in large, irregularly-shaped 'globs' falling into the weld pool under the action of gravity. Carbon dioxide gas drops are dispersed haphazardly. With argon-based gases, the drops are not as large and are transferred in a more axial direction. There is a lot of spatter, especially in carbon dioxide, resulting in greater wire consumption, poor penetration and poor appearance. Globular transfer occurs between the dip and spray ranges. This mode of transfer is not recommended for normal welding applications and may be corrected when encountered by either decreasing the arc voltage or increasing the amperage. Globular transfer can take place with any electrode diameter.

Basic flux-cored wires tend to operate in a globular mode or in a globular-spray transfer mode where larger than normal spray droplets are propelled across the arc, but they never achieve a true spray transfer mode. This transfer mode is sometimes referred to as non-axial globular transfer.

Self-shielded flux-cored wires operate in a predominantly globular transfer mode although at high currents the wire often 'explodes' across the arc.

Spray Transfer

In spray transfer, metal is projected by an electromagnetic force from the wire tip in the form of a continuous stream of discrete droplets approximately the same size as the wire diameter. High deposition rates are possible and weld appearance and reliability are good. Most metals can be welded, but the technique is limited generally to plate thicknesses greater than 6mm. Spray transfer, due to the tendency of the large weld pool to spill over, cannot normally be used for positional

welding. The main exception is aluminium and its alloys where, primarily because of its low density and high thermal conductivity, spray transfer in position can be carried out.

The current flows continuously because of the high voltage maintaining a long arc and short-circuiting cannot take place. It occurs best with argon-based gases.

In solid wire MIG/MAG, as the current is increased, dip transfer passes into spray transfer via a transitional globular transfer mode. With metal-cored wires there is virtually a direct transition from dip transfer to spray transfer as the current is increased.

For meta-cored wire spray transfer occurs as the current density increases and an arc is formed at the end of the filler wire, producing a stream of small metal droplets. Often the outside sheath of the wire will melt first and the powder in the centre flows as a stream of smaller droplets into the weld pool. This effect seems to give much better transfer of alloying elements into the weld.

In spray transfer, as the current density increases, an arc is formed at the end of the filler wire, producing a stream of small metal droplets. In solid wire MIG/MAG this transfer mode occurs at higher currents. Flux-cored wires do not achieve a completely true spray transfer mode but a transfer mode that is almost true spray may occur at higher currents and can occur at relatively low currents depending on the composition of the flux.

Rutile flux-cored wires will operate in this almost-spray transfer mode, at all practicable current levels. They are also able to operate in this mode for positional welding too. Basic flux-cored and self-shielded flux-cored wires do not operate in anything approaching true spray transfer mode.

Typical Metal Transfer Mode

Process	Dip Transfer	Globular Transfer	Spray Transfer
Metal Inert Gas (MIG) Metal Active Gas (MAG)	✓	✗	✓
Flux Cored (Gas Shielded)	✓	✓	✓*
Flux Cored (Self Shielded)	✓	✓	✗
Metal Cored	✓	✗	✓

* Not True Spray

Pulsed Transfer

Pulsed arc welding is a controlled method of spray transfer, using currents lower than those possible with the spray transfer technique, thereby extending the applications of MIG/MAG welding into the range of material thickness where dip transfer is not entirely suitable. The pulsed arc equipment effectively combines two power sources into one integrated unit. One side of the power source supplies a background current which keeps the tip of the wire molten. The other side produces pulses of a higher current that detach and accelerate the droplets of metal into the weld pool. The transfer frequency of these droplets is regulated primarily by the relationship between the two currents. Pulsed arc welding occurs between ± 50 -220A, 23-35 arc volts and only with argon and argon-based gases. It enables welding to be carried out in all positions.

2.5 Fundamentals of MIG/MAG, FCAW and MCAW

Welding Technique

Successful welding depends on the following factors:

- 1 Selection of correct consumables
- 2 Selection of the correct power source
- 3 Selection of the correct polarity on the power source
- 4 Selection of the correct shielding gas
- 5 Selection of the correct application techniques
 - a Correct angle of electrode to work
 - b Correct electrical stickout
 - c Correct travel speed
- 6 Selection of the welding preparation

Selection of Correct Consumable

Chemical composition

As a general rule the selection of a wire is straight forward, in that it is only a matter of selecting an electrode of similar composition to the parent material. It will be found, however, that there are certain applications that electrodes will be selected on the basis of its mechanical properties or level of residual hydrogen in the weldmetal. Solid MIG/MAG wires are all considered to be of the 'low Hydrogen type' consumables.

The following table gives a general overview of the selection of some of the BOC range of MIG/MAG wires for the most common materials.

Cast and Helix

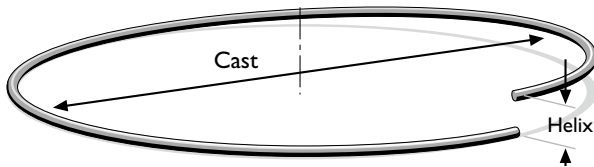

Cast – Diameter of the circle

Helix – Vertical height

Common Materials Welded with BOC MIG Wire

Material	BOC MIG Wire
AS2074 C1,C2,C3,C4-1,C4-2,C5,C6	BOC Mild Steel MIG Wire
AS/NZS1163 C250	BOC Mild Steel MIG Wire
AS/NZS3678 200,250,300	BOC Mild Steel MIG Wire
ASTM A36,A106	BOC Mild Steel MIG Wire
Stainless Steel	
Grade 304/L	BOC Stainless Steel 308LSi
Grade 309	BOC Stainless Steel 309LSi
Grade 316/L	BOC Stainless Steel 316LSi

Physical condition

Surface condition

The welding wire must be free from any surface contamination including mechanical damage such as scratch marks.

A simple test for checking the surface condition is to run the wire through a cloth that has been dampened with acetone for 20 secs. If a black residue is found on the cloth the surface of the wire is not properly cleaned.

Cast and Helix

The cast and helix of the wire has a major influence on the feedability of MIG/MAG wire.

If the cast is too large the wire will move in an upward direction from the tip when welding and if too small the wire will dip down from the tip. The result of this is excessive tip wear and increased wear in the liners.

If the helix is too large the wire will leave the tip with a corkscrew effect.

Selection of the Correct Power Source

Power sources for MIG/MAG welding is selected on a number of different criteria, including:

- 1 Maximum output of the machine
- 2 Duty cycle
- 3 Output control (voltage selection, wire feed speed control)
- 4 Portability

The following table gives an indication of the operating amperage for different size wires.

Wire Size	Amperage Range (A)
0.8 mm	60–180
0.9 mm	70–250
1.0 mm	90–280
1.2 mm	120–340

Selection of the Correct Polarity on the Power Source

Many power sources are fitted with an optional reverse polarity dinse connector.

To achieve the optimum welding it is important to adhere to the consumable manufacturer's instruction to select the polarity.

As a general rule all solid and metal cored wires are welded on electrode positive. (Work return lead fitted to the negative connector.)

Some grades of self-shielded flux-cored wires (i.e. E71T-11, E71T-GS etc) needs to be welded on electrode negative. (Work return lead fitted to the positive connector.)

Selection of the Correct Shielding Gas

The selection of the shielding gas has a direct influence on the appearance and quality of the weldbead.

The thickness of the material to be welded will determine the type of shielding gas that has to be selected. As a general rule the thicker the material (C-Mn and Alloy steels) are the higher the percentage of CO₂ in the shielding gas mixture.

Different grades of shielding are required for materials such as stainless steel, aluminium and copper.

The following table gives an indication of the most common shielding gases used for Carbon Manganese and alloy steel.

Material thickness	Recommended shielding gas
1–8 mm	Argoshield Light
5–12 mm	Argoshield Universal
>12 mm	Argoshield Heavy

More detailed selection charts, including recommendations for welding parameters (voltage, amperage, electrical stickout, travel speed and gas flow rate) can be found in the following pages.

2.6 4T/2T Trigger Latch Selection

On all MIG machines there is no current or wire feed until the trigger on the torch is depressed. If a welder is doing a lot of welding then he has to hold the trigger down for long periods of time and may cause discomfort. This can be similar to repetitive strain injury (RSI) that has become a very popular topic for compensation by office workers.

On all machines a special function called 2T and 4T is available. Also referred to as trigger latching, this special feature allows the operator to relax the trigger after first depressing it, the gas shielding to start before the welding commences. This feature is of particular importance as it ensures that the weld will have adequate gas shielding to eliminate the risk of oxidation (contaminants) causing a defective weld. (Remember, a defective weld may not be detected by a visual inspection.)

The 2T/4T function also allows for the shielding gas to continue after the weld has finished and cooled. This eliminates the risk of oxidation while the weld is still in its molten state. This is particularly important when welding stainless steel materials.

3.0 General Welding Information

3.1 Recommended Welding Parameters for MIG/MAG

Argoshield Light

Indicative Welding Parameters	Dip Transfer				Spray Transfer
	1-1.6	2	3	4	3
Material thickness (mm)	1-1.6	2	3	4	3
Welding position	Horizontal / Vertical	Horizontal / Vertical	Horizontal / Vertical	Horizontal / Vertical	Horizontal
Wire diameter (mm)	0.8-0.9	0.8-0.9	0.8-0.9	0.9-1.0	0.8
Current (amps)	45-80	60-100	80-120	80-150	160-180
Voltage (volts)	14-16	16-17	16-18	16-18	23-25
Wire feed speed (m/min)	3.5-5.0	4.0-7.0	4.0-7.0	4.0-7.0	7.5-9.0
Gas rate flow (L/min)	15	15	15	15	15
Travel speed (mm/min)	350-500	350-500	320-500	280-450	800-1000

Stainshield (Aus) or Stainshield Light (NZ)

Indicative Welding Parameters	Dip Transfer		
	4	6	8
Material thickness (mm)	4	6	8
Welding position	Horizontal / Vertical	Horizontal / Vertical	Horizontal / Vertical
Wire diameter (mm)	0.9-1.0	0.9-1.0	0.9-1.0
Current (amps)	100-125	120-150	120-150
Voltage (volts)	17-19	18-20	18-20
Wire feed speed (m/min)	5.0-6.5	6.0-7.5	6.0-8.0
Gas rate flow (L/min)	15	15	18
Travel speed (mm/min)	400-600	280-500	280-450

4.0 Correct Application Techniques

Electrical stickout

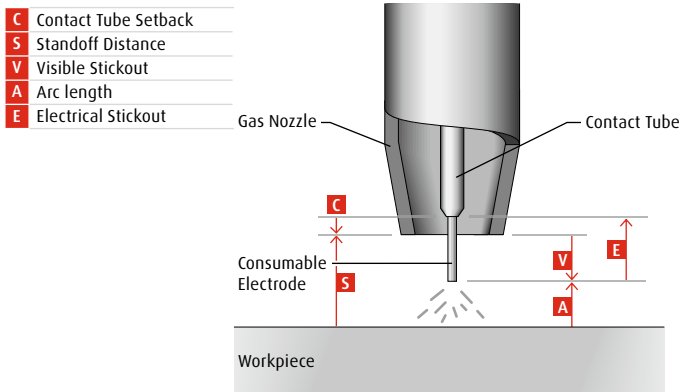

Correct Application Techniques

Direction of welding.

MIG/MAG welding with solid wires takes place normally with a push technique. The welding torch is tilted at an angle of 10° towards the direction of welding. (Push technique)

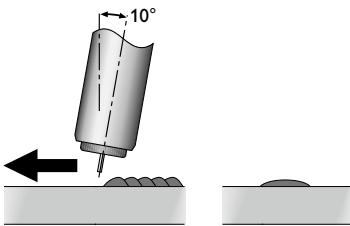

The influence of changing the torch angle and the welding direction on the weld bead profile can be seen below.

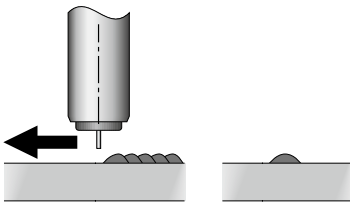

Torch perpendicular to workpiece narrow bead width with increased reinforcement.

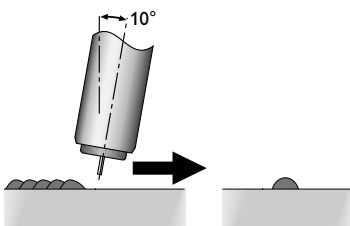

Torch positioned at a drag angle of 10° narrow bead with excessive reinforcement.

Flux cored welding with cored wires takes place normally with the drag technique. The welding torch is tilted at an angle of 10° away from the direction of welding. For all other applications the torch angle remains the same.

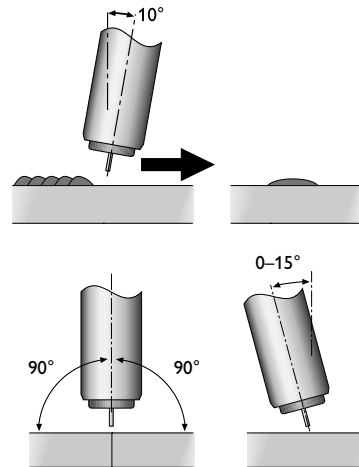

Torch position for butt welds

When welding butt welds the torch should be positioned within the centre of the groove and tilted at an angle of ±15° from the vertical plane. Welding is still performed in the push technique.

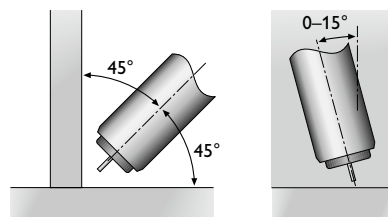

Electrical stickout

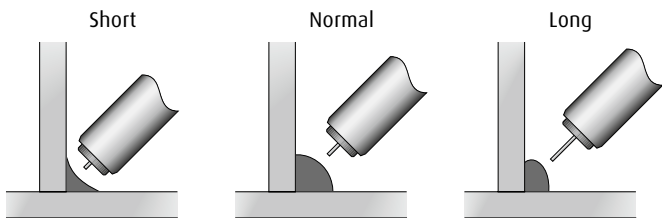

Travel speed

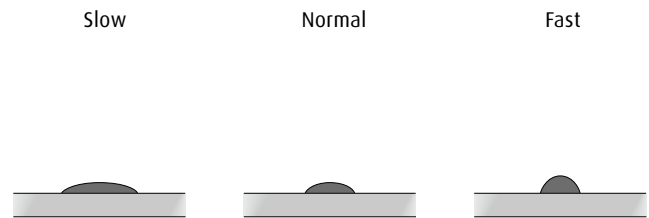

Torch position for fillet welds

When welding fillet welds the torch should be positioned at an angle of 45° from the bottom plate with the wire pointing into the fillet corner. Welding is still performed in the push technique.

Electrical stickout

The electrical stickout is the distance between the end of the contact tip and the end of the wire. An increase in the electrical stickout results in an increase in the electrical resistance. The resultant increase in temperature has a positive influence in the melt-off rate of the wire that will have an influence on the weldbead profile.

Influence of the change in electrical stickout length on the weldbead profile.

The travel speed will have an influence on the weldbead profile and the reinforcement height.

If the travel speed is too slow a wide weldbead with excessive rollover will result. Contrary if the travel speed is too high a narrow weldbead with excessive reinforcement will result.

5.0 Package Contents

Package consists of the following:

- Power source
- Work return lead
- Binzel MB15AK MIG/MAG torch
- Regulator
- Gas hose
- Spare feed rolls
- Operating manual

6.0 Smootharc MIG 180 Installation

Installation for MIG/MAG process

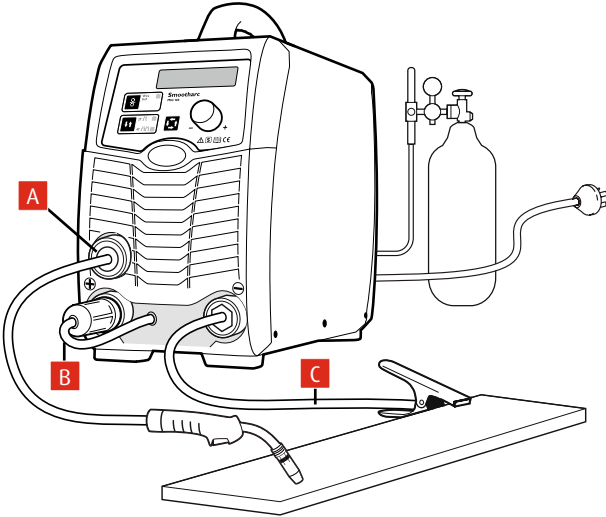

6.1 Installation for MIG/MAG process

- 1 Connect the gas cylinder to the regulator. Select correct shielding gas for the application.
- 2 Insert the earth return lead connection into the front panel.
- 3 Fit the wire spool to the machine. Select correct welding wire for application.
- 4 Select the appropriate feed roller to suit the wire being used
 - This machine comes complete with two types of wire feed rollers
 - V groove for use with solid carbon manganese and stainless steels
 - U groove for use with soft wires such as aluminium
- 5 Loosen the wire feed tension screws and insert the wire. Re fit and tension rollers ensuring the wire is gripped sufficiently so as not to slip but avoid over tightening as this can affect feed quality and cause wire feed components to wear rapidly.
- 6 Fit and tighten the torch on the output connection [A]. Ensure correct torch liner and contact tip are selected.
- 7 Select the correct polarity for the type of wire used as indicated on the consumable packaging. This is achieved by swapping the polarity terminal wires. For most solid wires the terminal should be set as torch positive.
- 8 For torch positive, plug the short mechanical connector (link plug) [B] on the front panel into the positive (+) terminal and the work return lead [C] into the negative (-) terminal.
- 9 For torch negative, couple the short mechanical connector [B] into the terminal marked negative (-), and the work return lead [C] into the positive (+) terminal.

7.0 Control panel

Front Panel of MIG 180

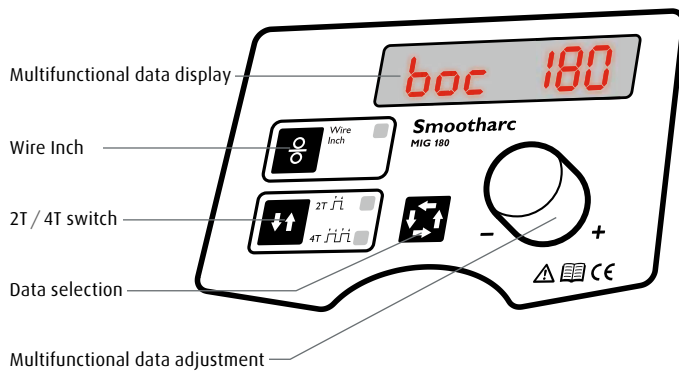

Multifunctional data adjustment

Coarse adjustments made by pressing and turning the knob.

Fine adjustments made by only turning the knob.

7.1 Polarity selection

The polarity on this machine can be reversed if so required for certain types of self-shielded wires. This can be achieved by switching the work return lead from the negative (-) to the positive (+) dinse socket.

8.0 Smootharc MIG 180 Operation

Illustration 1. Start-up display

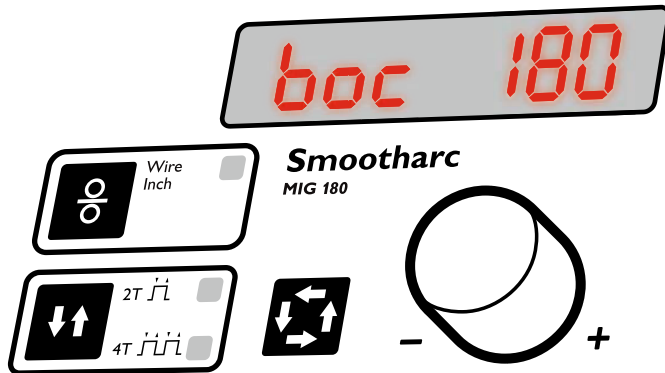

8.1 Starting up

Switch on the welding power source. The front panel display will light up as shown in Illustration 1. After the *Multifunctional Data display* (or any key or knob on front panel) flashes for 5 seconds, the machine enters into the welding mode that was saved in the last shutdown.

Illustration 2. Preset voltage

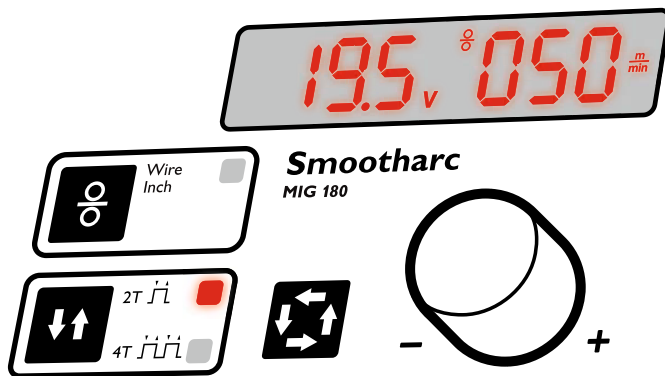
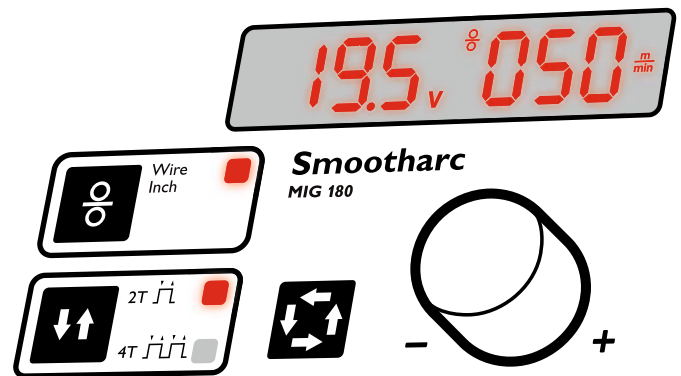

Illustration 3. Wire Check



8.2 Operation instruction

The wire can be fed through the system by pressing the *Wire Inch* button.

To feed the wire through the torch the *Wire Inch* button has to be pressed to feed the wire. To stop feeding the wire release the button.

In both illustrations shown above the *Multifunctional Data display* shows a preset voltage of 19.5V and a wire feed speed of 05.0m per minute.

The welding mode (2T/4T) can be selected by depressing the 2T/4T. The selected mode will illuminate. (Refer to the section on MIG Fundamentals on page 15 of this manual for an explanation of 2T and 4T operation).

The welding parameters can be adjusted during welding by turning the *Multifunctional Data adjustment*. This action will synergically change both parameters (volts and wire feed speed).

The synergic welding parameter range is 17.5V 2.0m/min to 25.8V 12m/min.

Illustration 4. Fine adjustment of voltage range

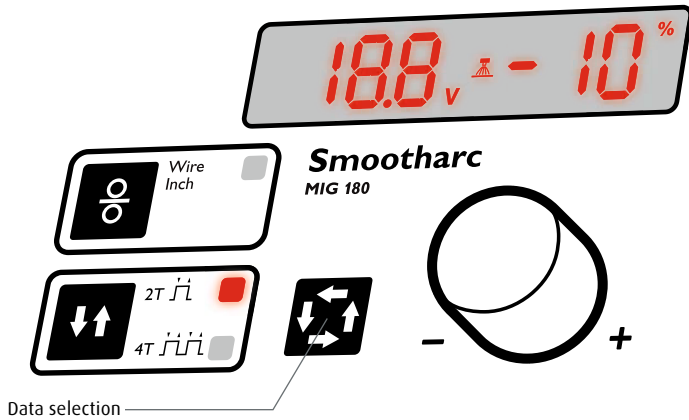
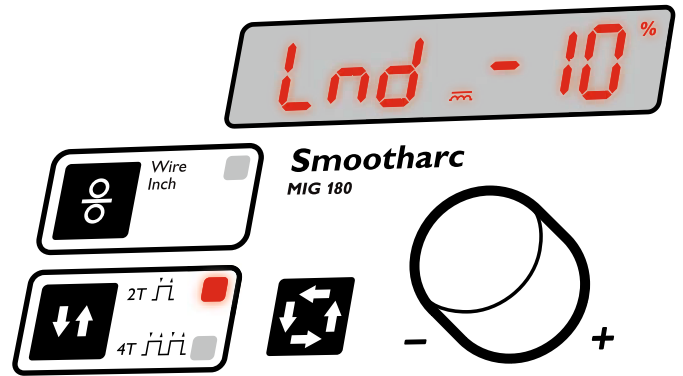

Illustration 5. Fine adjustment of Inductance presetting range



Pressing the *Data Selection* button will enable you to switch between:

- 1 Arc welding adjustment mode
- 2 Inductance
- 3 Preset voltage and wire speed

By pressing the *Data Selection* button the *Multifunctional Data display* will change according to the welding parameter function mode that can be changed. In Illustration 4, it displays the arc voltage and the adjustment that can be done. In this mode the arc voltage is adjustable and the adjustment range of the preset value is $\pm 20\%$.

When the *Data Selection* button is pressed again the *Multifunctional Data Display* will change to display the inductance as shown in Illustration 5. In this mode the inductance is adjustable and its adjustment range is $\pm 10\%$.

When the *Data Selection* key is pressed again the *Multifunctional Data Display* will return to the preset voltage and wire feed speed.

If settings are unchanged for three seconds the *Multifunctional Data Display* will flash once to indicate that the setting has been saved and these will be retained, and displayed when the machine restarts.

9.0 Troubleshooting and Fault Finding

9.1 MIG/MAG functions

Power source

Component	Fault symptom	Cause
Primary cable	No or low welding output	Poor or incorrect primary connection, lost phase
Earth cable and clamp	Arc will not initiate	Damaged, loose or undersized cables and clamps
Connectors and lugs	Overheating of connectors and lugs	Loose or poorly crimped connectors
Switches	Erratic or no output control	Switches damaged or incorrectly set for the application

Wire feeder

Component	Fault symptom	Cause
Gas solenoid valve	No gas flow or gas flows continuously	Gas valve faulty or sticking in open position
Wire feed rolls	Wire slippage, wire deformation	Incorrect feed roll size, incorrect tension adjustment, misalignment
Inlet, outlet guides	Wire shaving or snarling	Incorrect wire guide sizes, misalignment
Torch connector	Wire restriction, gas leaks, no trigger control	Torch connector not correctly mounted or secured, incorrect size of internal guide, bent contact pins
Wire feed speed control	No control over wire feed speed, no amperage control	Faulty wire speed feed potentiometer, machine in overload or trip condition
Wire inch switch	Wire live when feeding through cable and torch before welding	Faulty wire inch switch, activation of torch trigger switch
Spindle	Wire spool drags or overruns	Spindle brake set too tight or too loose, spool not properly located on spindle

Welding torch

Component	Fault symptom	Cause
Type	Welding torch overheats	Welding torch underrated for welding application
Liners	Erratic wire feed, wire snarls up at outlet guide	Liner of incorrect type and size for wire in use, worn or dirty liner, liner too long or too short
Gas distributor	Inadequate gas flow, contaminated or porous weld	Damaged or blocked distributor
Nozzle	Inadequate gas cover, restricted joint accessibility	Nozzle too large or too small, incorrect length or shape
Contact tip	Erratic feeding, wire shudder, wire burnback, unstable arc, spatter	Incorrect size of contact tip, incorrect contact tip to nozzle distance for metal transfer mode, tip has worn out
Nozzle insulator	Arcing between contact tip and nozzle and between nozzle and workpiece	No nozzle insulator fitted, spatter build up has caused parts to short out

Regulator / flowmeter

Component	Fault symptom	Cause
Inlet stem	No gas flow, gas leaks at regulator body or cylinder valve	Blocked inlet stem, leaking inlet stem to body thread, bullnose not properly seated in cylinder valve
Gas hose and fitting	Leaks at connections or in the hose, porosity in the weld	Poorly fitted loose connections, damaged hose, air drawn into gas stream

Welding wire

Component	Fault symptom	Cause
Wire basket and spool	Erratic wire feeding or wire stoppages	Damaged wire basket, loose spooling, random-wound wire
Wire	Wire sticks in contact tip, erratic feeding	Varying wire diameter, copper flaking, surface damage
Wire	Weld has excessive amount of spatter	Wrong polarity has been selected

Porosity in Weld Deposit

Cause	Solution
Entrapped impurities, hydrogen, air, nitrogen, water vapour	Do not weld on wet material.
Defective gas hose or loose connection	Check hoses and connections for leaks
Filler material is damp (particularly aluminium)	Dry filler metal in oven prior to welding
Filler material is oily or dusty	Replace filler metal
Alloy impurities in the base metal such as sulphur, phosphorous, lead and zinc	Change to a different alloy composition which is weldable. These impurities can cause a tendency to crack when hot
Excessive travel speed with rapid freezing of weld trapping gases before they escape	Lower travel speed
Contaminated shield gas	Replace the shielding gas

Inadequate shielding

Cause	Solution
Gas flow blockage or leak in hoses or torch	Locate and eliminate the blockage or leak
Excessive travel speed exposes molten weld to atmospheric contamination	Use slower travel speed or carefully increase the flow rate to a safe level without creating excessive turbulence. Use a trailing shield cup
Wind or drafts	Set up screens around the weld area
Excessive electrode stickout	Reduce electrode stickout. Use a larger size nozzle
Excessive turbulence in gas stream	Change to gas saver parts or gas lens, lower flow rate if possible

10.0 Periodic Maintenance

WARNING

Only authorised electricians should carry out repairs and internal servicing.

Modification of the 15A primary input plug or fitment of a lower rated primary input plug will render the warranty null and void.

The working environment or amount of use the machine receives should be taken into consideration when planning maintenance frequency of your Smootharc welder.

Preventative maintenance will ensure trouble-free welding and increase the life of the machine and its consumables.

10.1 Power Source

- Check electrical connections of unit at least twice a year.
- Clean oxidised connections and tighten.
- Inner parts of machine should be cleaned with a vacuum cleaner and soft brush.
- Do not use any pressure-washing devices.
- Do not use compressed air as pressure may pack dirt even more tightly into components.

11.0 Technical Specifications

Specifications

MIG 180

Part No.	BOC180MIG
Power voltage	Single phase 240V \pm 15 %
Frequency	50/60Hz
Rated input plug	15 A
Output current	50 to 175 A
Rated working voltage	16.5 to 22.8V
No-load voltage	56 V
Duty cycle	35 %
Wire feeder	Internal
Wire feeder speed	2 to 12 m/min
Welding wire diameter	0.6/0.8/1.0 mm
Remote control	No
Efficiency	80 %
Power factor	0.73
Insulation grade	F
Housing protection grade	IP23S
Welding thickness (mm)	>0.8 mm
Dimensions L x W x H	420 x 220 x 439 mm
Weight	12.8 kg
Standards	IEC 60974.1

12.0 Warranty Information

12.1 Terms of Warranty

The Smootharc machine has a limited warranty that covers manufacturing and material defects only. The warranty is affected on the day of purchase and does not cover any freight, packaging and insurance costs. Verbal promises that do not comply with terms of warranty are not binding on warrantor.

12.2 Limitations on Warranty

The following conditions are not covered under terms of warranty: loss or damage due to or resulting from natural wear and tear, non-compliance with operating and maintenance instructions, connection to incorrect or faulty voltage supply (including voltage surges outside equipment specs), incorrect gas pressure overloading, transport or storage damage or fire or damage due to natural causes (e.g. lightning or flood). This warranty does not cover direct or indirect expenses, loss, damage of costs including, but not limited to, daily allowances or accommodation and travelling costs.

Modification of the 15A primary input plug or fitment of a lower rated primary input plug will render the warranty null and void.

NOTE

Under the terms of warranty, welding torches and their consumables are not covered. Direct or indirect damage due to a defective product is not covered under the warranty. The warranty is void if changes are made to the product without approval of the manufacturer, or if repairs are carried out using non-approved spare parts. The warranty is void if a non-authorized agent carries out repairs.

12.3 Warranty Period

The warranty is valid for 18 months from date of purchase provided the machine is used within the published specification limits.

12.4 Warranty Repairs

A BOC approved service provider must be informed within the warranty period of any warranty defect. The customer must provide proof of purchase and serial number of the equipment when making a warranty claim. Warranty repairs may only be carried out by approved BOC service providers. Please contact your local BOC Gas & Gear for a directory of BOC approved service providers in your area.

For more information contact the BOC Customer Service Centre.

BOC Australia
131 262
contact@boc.com

BOC New Zealand
0800 111 333
customer.servicenz@boc.com

BOC Limited
10 Julius Avenue, North Ryde NSW 2113, Australia
www.boc.com.au

970-988 Great South Road, Penrose, Auckland, New Zealand
www.boc.co.nz